



# EMO CABLE TESTER INSTRUCTIONS FOR USE

**CAUTION: UNDER NO CIRCUMSTANCES SHOULD THE UNIT BE CONNECTED TO ANY EQUIPMENT WHICH IS IN OPERATION OR CONNECTED TO MAINS POWER.**

To ensure safe operation of this unit and equipment connected to it read the following and take the appropriate action.

## Models

- EMO Cable Tester E445 (25-445)
- EMO Cable Tester E446 (25-446)

## Description

The CABLE TESTER is a compact test set allowing the user to locate most continuity conditions within professional audio equipment. Internal connections on the CABLE TESTER are as follows:

BUTTON	JACK	XLR	PHONO
1	Sleeve	1	Shell
2	Tip	2	Tip
3	Ring	3	

The CABLE TESTER is powered by a 9V battery, type 4022, MN1604, 6LR61 or equivalent. (Old PP3 style.) The battery can be changed by removing the lid of the unit. When replacing the lid ensure that the battery lead is not trapped. Correct operation of the battery can be established by placing a short-circuit across the Fuse Test terminals and observing the LED in Button 3. If the LED is dull or fails to light then the battery should be replaced. The battery should be replaced at least annually to prevent any possible leakage.

## Cable Testing

- 1. 3-pin XLR & 3-pole jack leads** Insert both ends of the cable into the correct sockets and press each of the buttons in sequence. Consult Table 1 for interpretation of the results.
- 2. 2-pole jack leads** As in 1 but note that a 2-pole jack will short 1 & 3. (ring and sleeve).
- 3. Phono leads** As in 1 but note that a phono connector will indicate on buttons 1 and 2 only (shell and tip.)

## Fuse Testing

The unit will test most commonly used fuse links. Place the fuse across the Fuse Test terminals ensuring that the fuse end caps make good contact. If intact, the LED in Button 3 will light. Correct operation of this section may be confirmed by placing a screwdriver across the terminals. Other items, such as theatre lamps, etc., may be tested in this way if their connections have suitable spacing, e.g. Par 64 lamps, 15A round pin theatre lamps, etc.

## Continuity

By use of the Test Leads, continuity of external circuits may be checked and the result observed on the LED in Button 1. Please note that the LED will illuminate (with reduced brightness) even when considerable resistance is in circuit. This section also gives an audible indication.

When testing cables the CABLE TESTER cannot determine where the faults actually lie, only if the fault exists. For example, in the case of a cable shown to have an open circuit, the fault could lie in either of the connectors or in the cable itself. In these circumstances use of the continuity section of the CABLE TESTER can be invaluable. In the case of screened cables, connection of the screen to the correct pins can only be determined by a visual inspection.

**Table 1**

● ○ ○ 1 2 3 CONTINUITY 1	○ ● ○ 1 2 3 CONTINUITY 2	○ ○ ● 1 2 3 CONTINUITY 3
○ ● ○ 1 2 3 CROSS-WIRE 1-2	● ○ ○ 1 2 3 CROSS-WIRE 2-1	● ○ ○ 1 2 3 CROSS-WIRE 3-1
○ ○ ● 1 2 3 CROSS-WIRE 1-3	○ ○ ● 1 2 3 CROSS-WIRE 2-3	○ ● ○ 1 2 3 CROSS-WIRE 3-2
● ● ○ 1 2 3 SHORT 1-2	● ● ○ 1 2 3 SHORT 1-2	○ ● ● 1 2 3 SHORT 2-3
● ○ ● 1 2 3 SHORT 1-3	○ ● ● 1 2 3 SHORT 2-3	● ○ ● 1 2 3 SHORT 1-3
● ● ● 1 2 3 SHORT 1-2-3	● ● ● 1 2 3 SHORT 1-2-3	● ● ● 1 2 3 SHORT 1-2-3
○ ○ ○ 1 2 3 OPEN-CIRCUIT 1	○ ○ ○ 1 2 3 OPEN-CIRCUIT 2	○ ○ ○ 1 2 3 OPEN-CIRCUIT 3

← This line shows a correctly wired cable.

Note: On cables which show continuity faults it is possible for the cable also to be cross-wired, a condition which the CABLE TESTER will only show after the short has been corrected. It is therefore recommended that cables are checked after repair to ensure that all faults have been corrected.

Although the table may appear a little complicated, a short time spent experimenting with the CABLE TESTER should allow the user to identify faults in cables without needing to refer to the table.

## Notes

Where leads to be tested combine dissimilar connectors containing different numbers of pins, the test results may vary depending on which way round the lead is plugged into the CABLE TESTER. For example, if a test is to be carried out on a Phono to 2-pole Jack lead the readings will differ depending on whether the Phono plug or the Jack plug is inserted into the left hand side test connector. The logic is shown in Fig.1 and Fig.2.

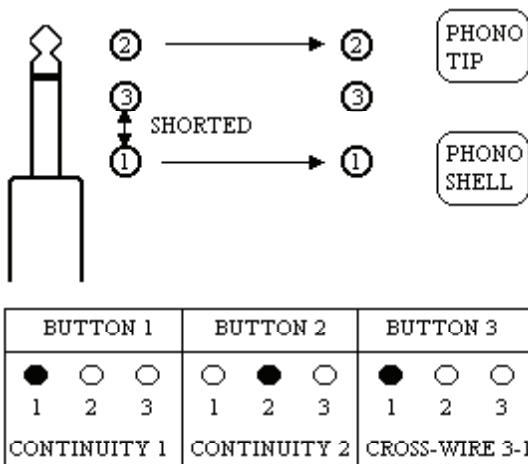

Fig. 1

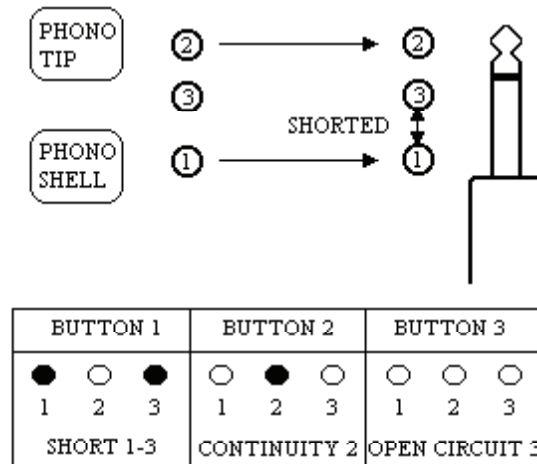

Fig. 2

For further information or servicing please contact your local E.M.O. Dealer.